

AUXXLIFT

Auxx-One

Installation Guide

Complete Installation & Setup Manual

Design and Quality — AUXXLIFT of the USA

All Rights Reserved • US Patent 9,572,427 B2

Release 10/2025 — Revised Edition

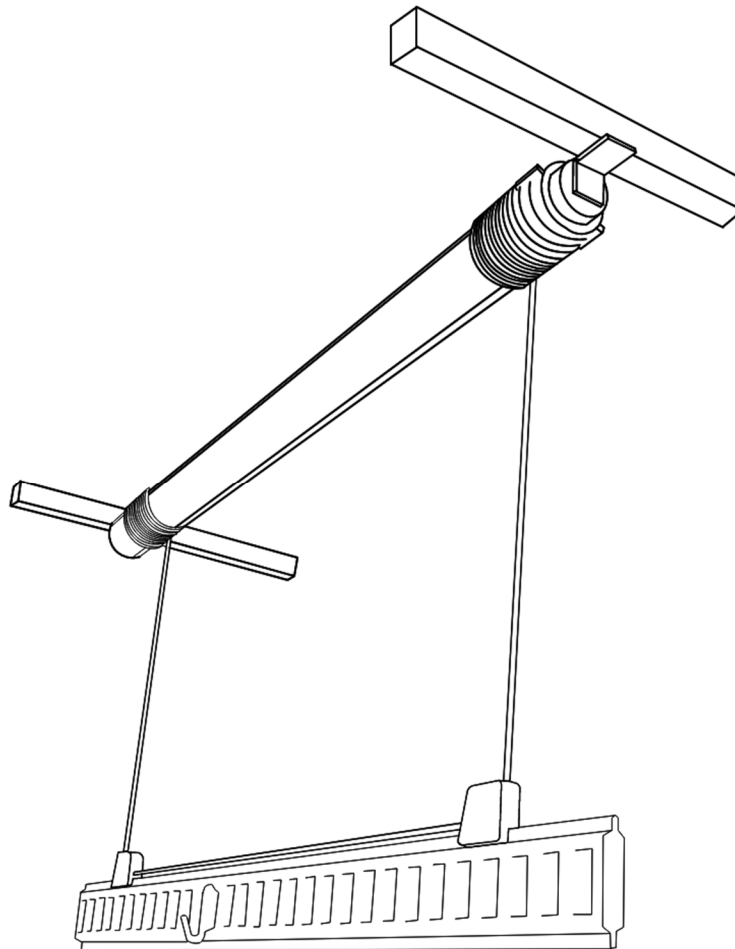

i Need Help?

Visit www.auxx-lift.com/installation-help for installation videos.

Help phone: PT 9 AM – 5 PM, Mon-Sat, at 1-888-915-5797

www.auxx-lift.com

Table of Contents

Table of Contents

- Table of Contents 2
- 1. Before You Start 4
 - 1.1 Pre-Installation Checklist 4
 - 1.2 Important Rules 4
 - 1.3 Ceiling Requirements 4
- 2. Recommended Tools 5
 - 2.1 Required Tools 5
 - 2.2 Nice to Have 6
- 3. Parts List 7
 - 3.1 Major Components 7
 - 3.2 Hardware 8
- 4. Planning Your Installation 10
 - 4.1 Minimum Required Area 10
 - 4.2 Joist Orientation 10
 - 4.3 Extra Materials for 90° Rotated Joists 11
 - 4.4 Do's and Don'ts 12
- 5. Step 1: Install Strut Channels 13
 - 5.1 Locate the Joists 13
 - 5.2 Mount the Strut Channels 13
 - 5.3 Strut Channel Mounting for 90° Rotated Joists 14
- 6. Step 2: Install Motor and Wiring 14
 - 6.1 Cable Direction 14
 - 6.2 Motor Positioning 14
 - 6.3 Mount the Motor 15
 - 6.4 Power Outlet Routing 16
- 7. Step 3: Wire Rope and Track (Beam) Install 17
 - 7.1 Unrolling the Wire Rope 17
 - 7.2 Assemble the Track Beam 17
- 8. Step 4: Motor Adjustment 19
 - 8.1 Remote Control 19
 - 8.2 Screw Locations 19
 - 8.3 Understanding + and – Directions 20
 - 8.4 Adjustment Overview 20
- 9. Step 5: Covers & Wire Mesh 22
 - 9.1 Install Strut Covers 22

10. Inspection Checklist.....	23
11. Remote Control Programming	24
11.1 Remote Control Layout.....	24
11.2 Pair Remote to Motor Controller	24
11.3 Normal Mode vs. DeadMan Mode	24
11.4 Set Number of Channels (Multiple Lifts)	24
11.5 Delete All Remote Pairings.....	25
11.6 Jog Mode / Continuous Mode.....	25

1. Before You Start

READ COMPLETELY BEFORE BEGINNING



Read through all instructions before starting the installation. For a professional, this installation takes approximately 3 hours. Follow the instructions carefully and in order. If you feel uncomfortable handling the installation, please ask a handyman or work with a contractor.

1.1 Pre-Installation Checklist

1. Have you read through the entire instructions?
2. Do you have all the recommended tools?
3. Do you have somebody assisting you?
4. Have you allocated enough time (minimum 3 hours)?
5. Do you have a good, stable ladder?

1.2 Important Rules

- Do not use an impact driver.
- Clean the work area before you start.
- Wear safety glasses at all times.
- Keep the work area clear of obstructions.
- Check measurements during construction.
- Make sure nothing is in the way (windows, doors, garage door tracks, etc.).

1.3 Ceiling Requirements

STRUCTURAL SAFETY



By proceeding with installation, the customer acknowledges and accepts full responsibility for verifying that their ceiling structure is adequate to support the lift and its rated load capacity. Auxx Lift assumes no liability for structural failures, property damage, or personal injury resulting from inadequate ceiling construction.

1. Does your garage ceiling have or has had termites?
2. Are the joists strong and big enough? (2" x 6" minimum); Always check with a structural engineer.
3. Mounting to a concrete ceiling requires anchors.
4. Has your home been built according to valid standards and guidelines?



Visit www.auxx-lift.com/installation-help for installation videos.
Help phone: PT 9 AM – 5 PM, Mon-Sat, at 1-888-915-5797
www.auxx-lift.com

2. Recommended Tools

2.1 Required Tools

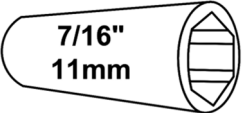
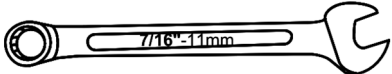
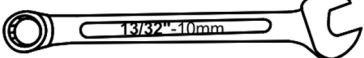
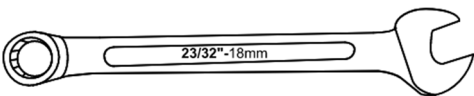
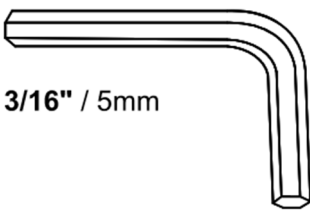
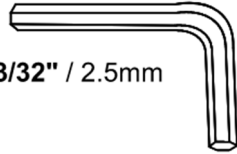
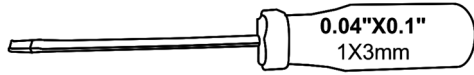
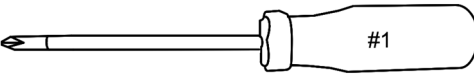
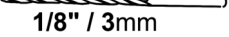
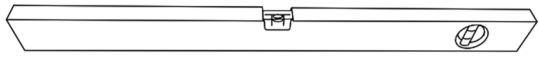
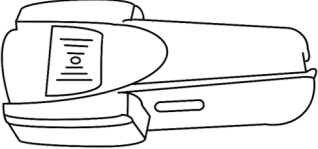
Tool	Image	Purpose
Socket wrench - 7/16" (11 mm)		Lag screws, bracket screws, spring nuts
Ratchet wrench - 7/16" (11 mm)		Tight spaces where socket won't fit
Ratchet wrench - 13/32" (10 mm)		Set screws and smaller hardware
Ratchet wrench - 23/32" (18 mm)		Motor mounting nuts
Allen key (hex wrench) - 3/16" (5 mm)		Platform assembly screws
Allen key (hex wrench) - 3/32" (2.5 mm)		Set screws
Flat-head screwdriver		Wiring connections, adjustment screws
Philips screwdriver		Mounting controller
Drill with drill bit - 1/8" (3 mm)		Pilot holes for lag screws for strut channel mounting
Level (24–48")		Leveling strut channels and beams
Stud finder		Locating ceiling joists

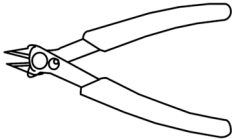
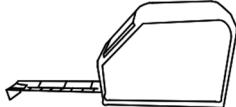
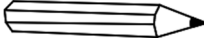
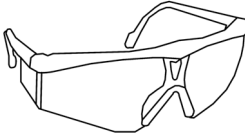
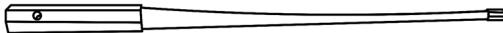
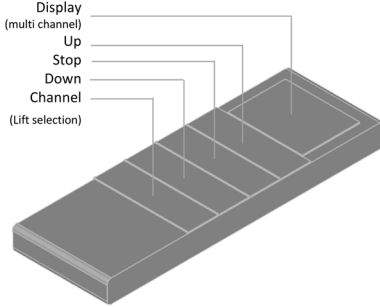
Wire cutters / snips		Cable ties
Tape measure		Measurements
Pencil		Marking joist locations
Safety glasses		Eye protection (required!)
Ladder	-	Reaching the ceiling
Adjustment Tool (provided)		Turning motor adjustment screws.
Remote Control (provided)		Moving lift up, down, stop, learn.

2.2 Nice to Have

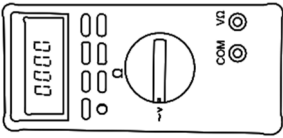
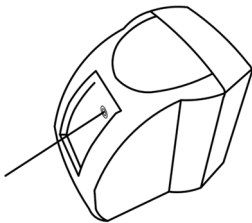
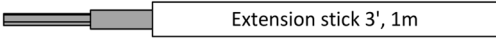
Tool	Image	Purpose
Multimeter		For checking electrical connections
Laser		For layout on ceiling
Headlamp		For working overhead
Extension stick (3 ft / 1 m)		For adjusting motors from the floor (not included).

3. Parts List







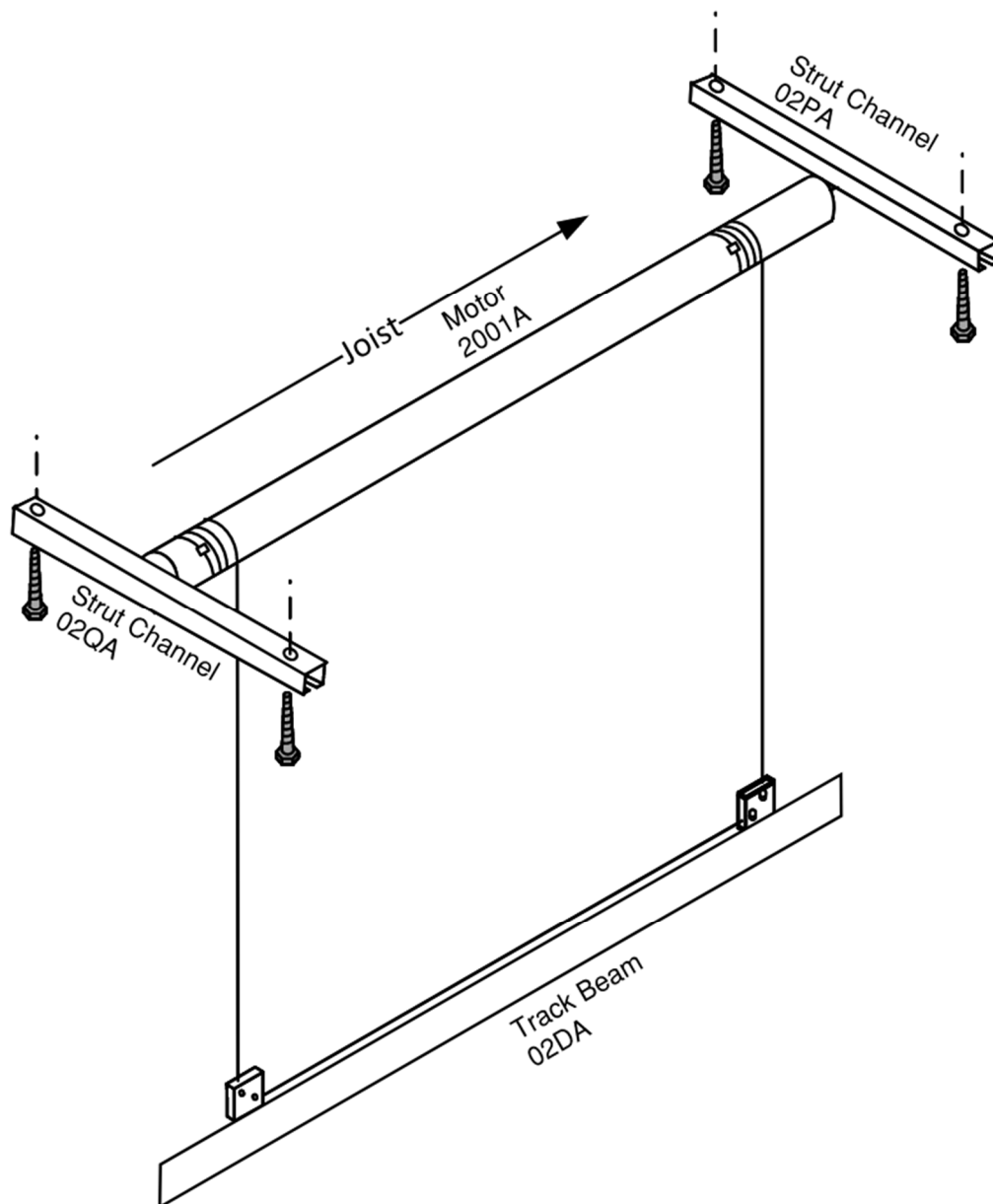

Verify all parts are included before beginning installation.

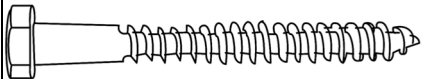
3.1 Major Components

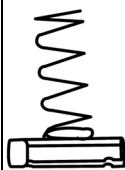
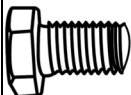
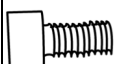
Qty	Part #	Description
1	2001A	Motor assembly (single motor)
2	02PA / 02QA (side holes)	Strut channel (1 with side holes, 1 without)
2	02DA	Track, 5' Beam

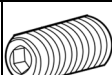
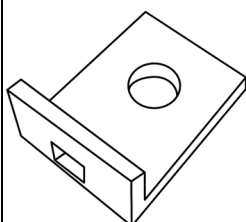

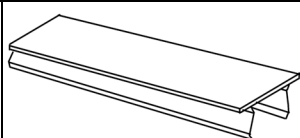
3.2 Hardware

Qty	Part #		Description
4	067A		Lag screws (5/16" x 4.0" / 8 mm x 100 mm SPAX); For strut channel attachment.
6	078A		Flat washers (M12, for lag screws)
4	07AA		Flat washers (M8)
2	074A		Spring nuts for motor attachment at strut channels
2	065A		Screws (M12x24)
12	063A		Screws (M6x14)
8	06HA		Screws (M6x20)
12	071A		Nuts (M6)
12	069A		Setting screw (M5 x 12mm)
2	022C		Motor Bracket
2	07FA		Cotter pins
1	013A		Strut cover at cables
2	03LA		Grommets for strut channel holes (controller side)
4	09FA		Cord grips

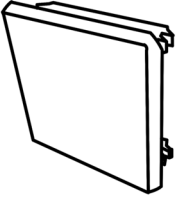
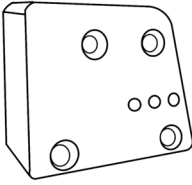
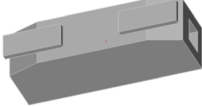
Qty	Part #		Description
4	03EA		Strut covers/end caps
2	011A / 012A		Left and right Cable guide holders
3	09GA		Cable connectors

4. Planning Your Installation

4.1 Minimum Required Area

The Auxxlift One requires the following minimum clearances between the strut channels and adjacent walls:

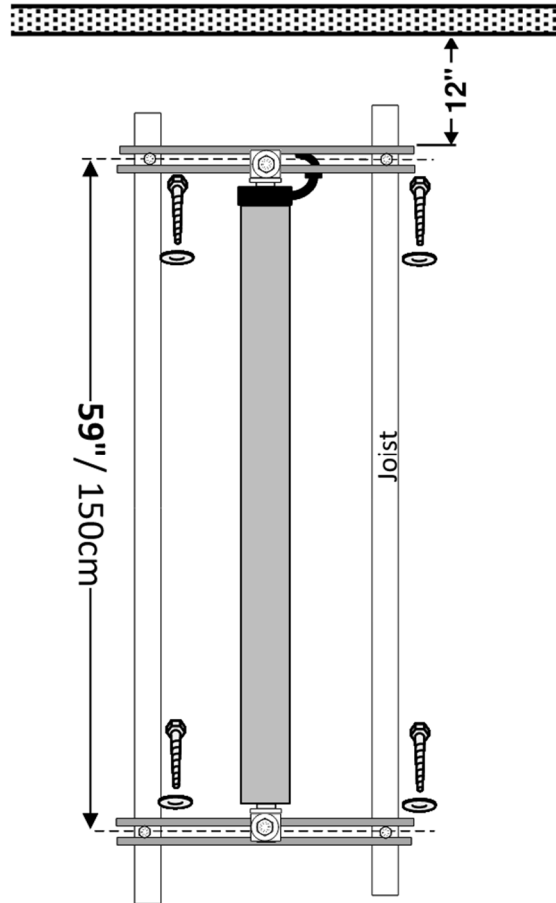

4.2 Joist Orientation

There are two installation configurations depending on your joist orientation:

Configuration	Joist Direction	What You Need
Standard (Option 1)	Joists run perpendicular to strut channels	Included hardware only
Rotated 90° (Option 2)	Joists run parallel to strut channels	Extra strut channels (not included — see Section 4.3)

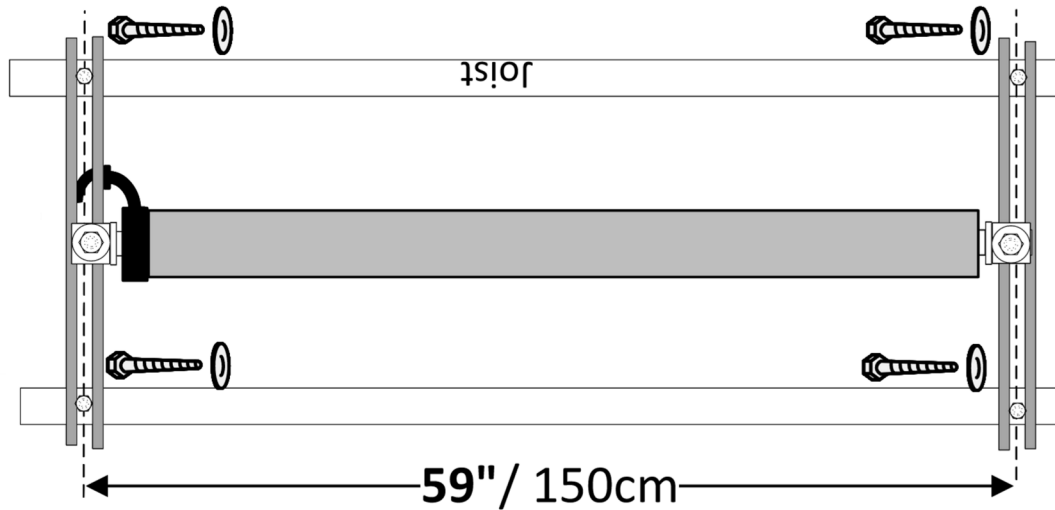

4.3 Extra Materials for 90° Rotated Joists

If your joists are rotated 90° from standard, you will need the following additional materials (available at any hardware store or from Auxxlift – model # below are from Home Depot if needed):

Qty	Description	Model #
2	Strut Channel 57.5" (146 cm)	ZA12HS10EG
8	Strut Spring Nuts 1/2"	ZA1001/2EG-10
8	Strut Screws Hex-Head Bolt	ZE142121516EG10
4	Strut Brackets	ZAB206EG-10
2	Strut Cover 57.5"	—

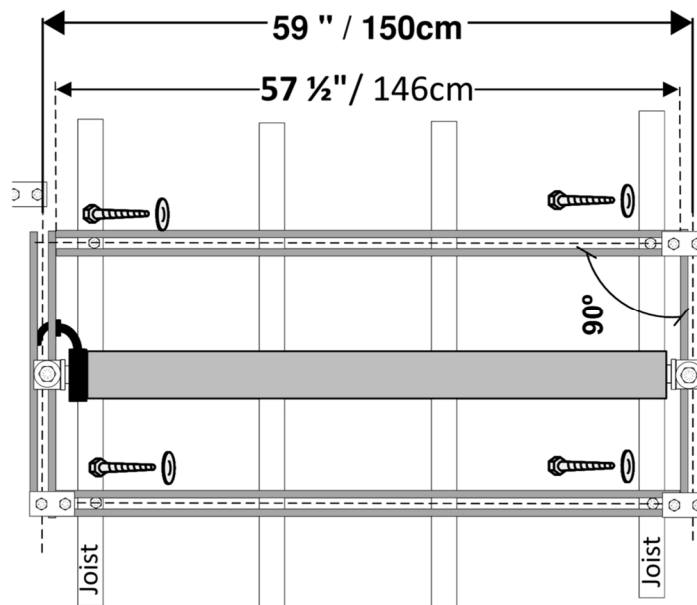

4.4 Do's and Don'ts

Do	Don't
Ensure gap between bracket and motor is less than 1/16" (1 mm)	Use an impact driver on lag screws
Route motor cable straight up toward the ceiling	Change any material
Use grommets on all wire paths into struts	Cut the wire rope
	Drill additional holes in any parts

5. Step 1: Install Strut Channels

The strut channels mount directly to the ceiling joists and form the rail system for the lift.

5.1 Locate the Joists

1. Use a stud finder to locate the ceiling joists.
2. Mark the joist locations with a pencil. Ensure the lag screw will be installed at the center of the joist.
3. Drill pilot holes using a 1/8" (3 mm) drill bit.

5.2 Mount the Strut Channels

1. Identify the two strut channels: one has side holes, one does not.
2. **The strut channel WITH side holes is the controller side.**
3. **The strut channel WITHOUT side holes is the opposite side.**
4. Position the strut channels 59" / 150 cm apart (center to center), perpendicular to the joists.
5. Ensure both channels are level and at 90° to each other.
6. Secure each channel with lag screws (5/16" x 4.0" / 8 mm x 100 mm SPAX) (4 total) and flat washers (M8 and M12).
7. Install grommets (2x) at side holes of the controller-side strut channel.

LAG SCREW WARNING



DO NOT use an impact driver to tighten the lag screws! Tighten each screw until the washer no longer rotates. Then tighten the screw another 90° in the same direction.

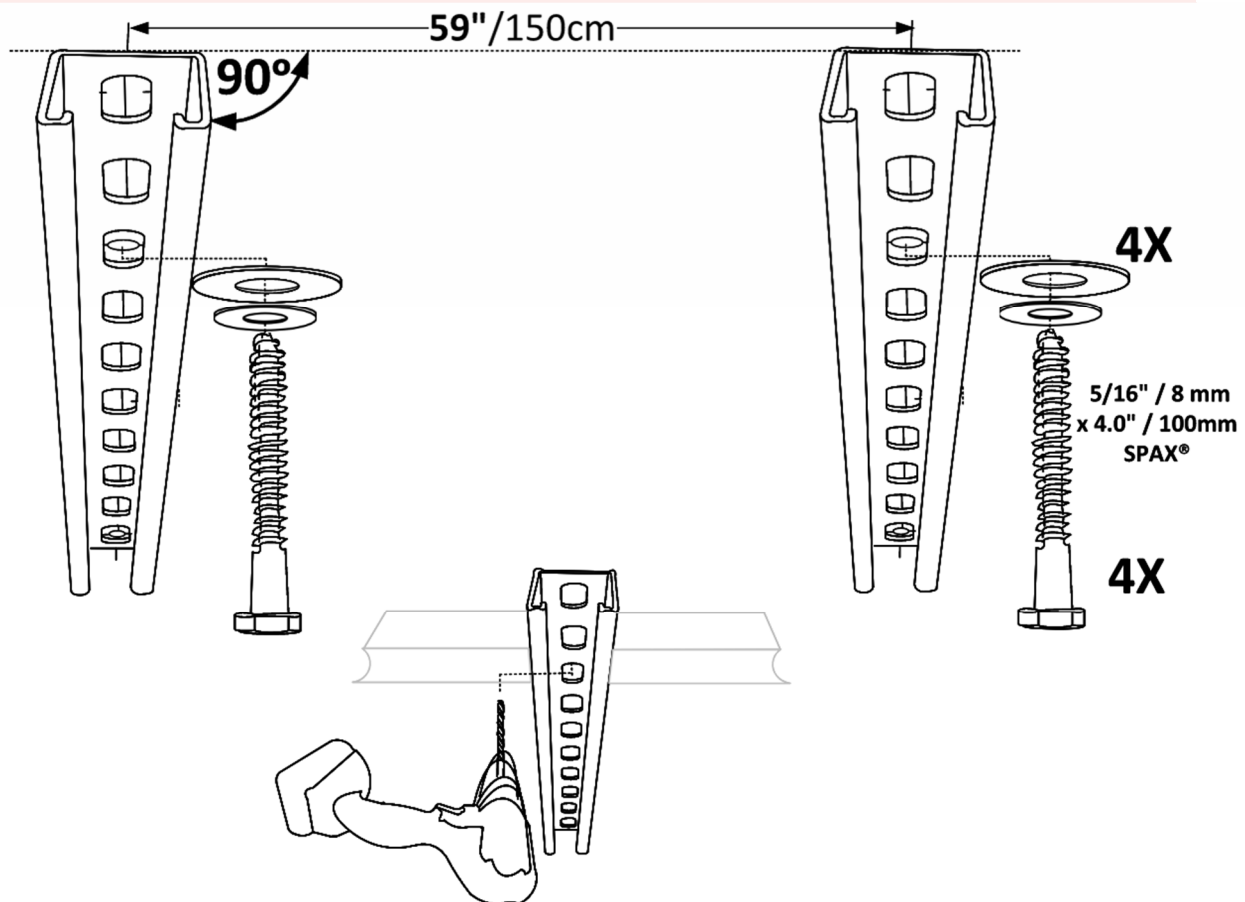

5.3 Strut Channel Mounting for 90° Rotated Joists

If your joists run parallel to the strut channels, mount a cross-strut channel perpendicular to the joists first, using the additional hardware kit (see Section 4.3). Then attach the main strut channels to the cross-strut using strut brackets and spring nuts at the correct 59" / 150 cm spacing.

6. Step 2: Install Motor and Wiring

i The Auxxlift One uses a single motor assembly mounted centrally between the two strut channels.

6.1 Cable Direction

CABLE DIRECTION
 The black cable that comes out of the motor must be routed straight up to the ceiling. Ensure the cable is routed properly before securing.

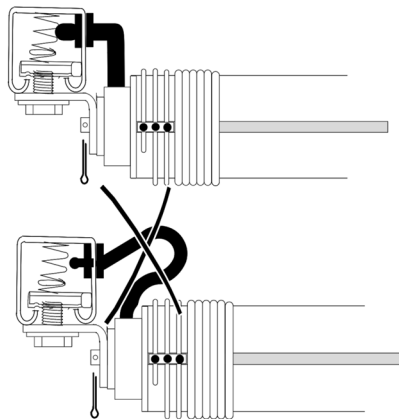

6.2 Motor Positioning

The motor should be mounted centered between the two strut channels, at the midpoint of the strut channel length.

Measurement	Value
Motor position (center of strut channel)	Centered — 15" / 38 cm from each end



6.3 Mount the Motor

1. Slide spring nuts (2x) (074A) into each strut channel at the motor position.
2. Position the motor brackets (2x) (022C) on the spring nuts at the correct location.
3. Attach the motor to the strut channels using the brackets (022C), M12x24 screws (0605A), and washers (078A). Tighten the M12x24 screw until the washer no longer rotates, then tighten another 135 degrees using a ratchet wrench (23/32" / 18 mm).

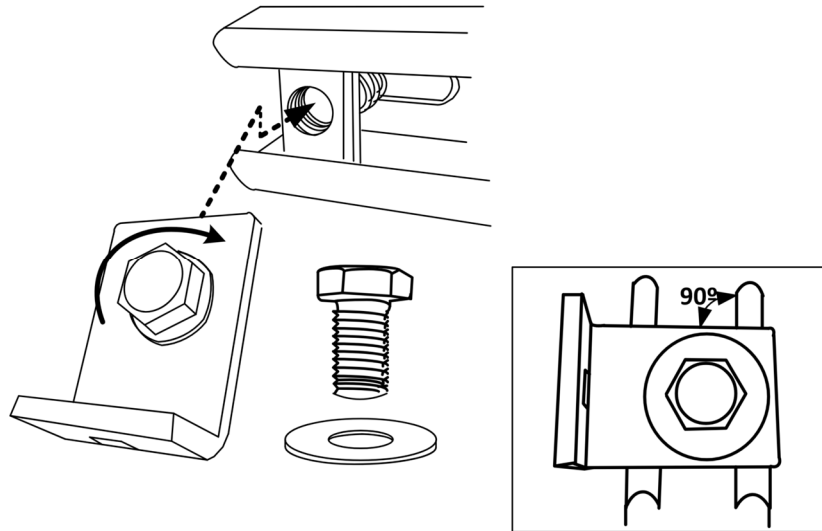

4. Verify the gap between the bracket and motor does not exceed 1/16" (1 mm).
5. Insert the (2x) cotter pins (07FA) into the bracket securing holes and bend open to lock.

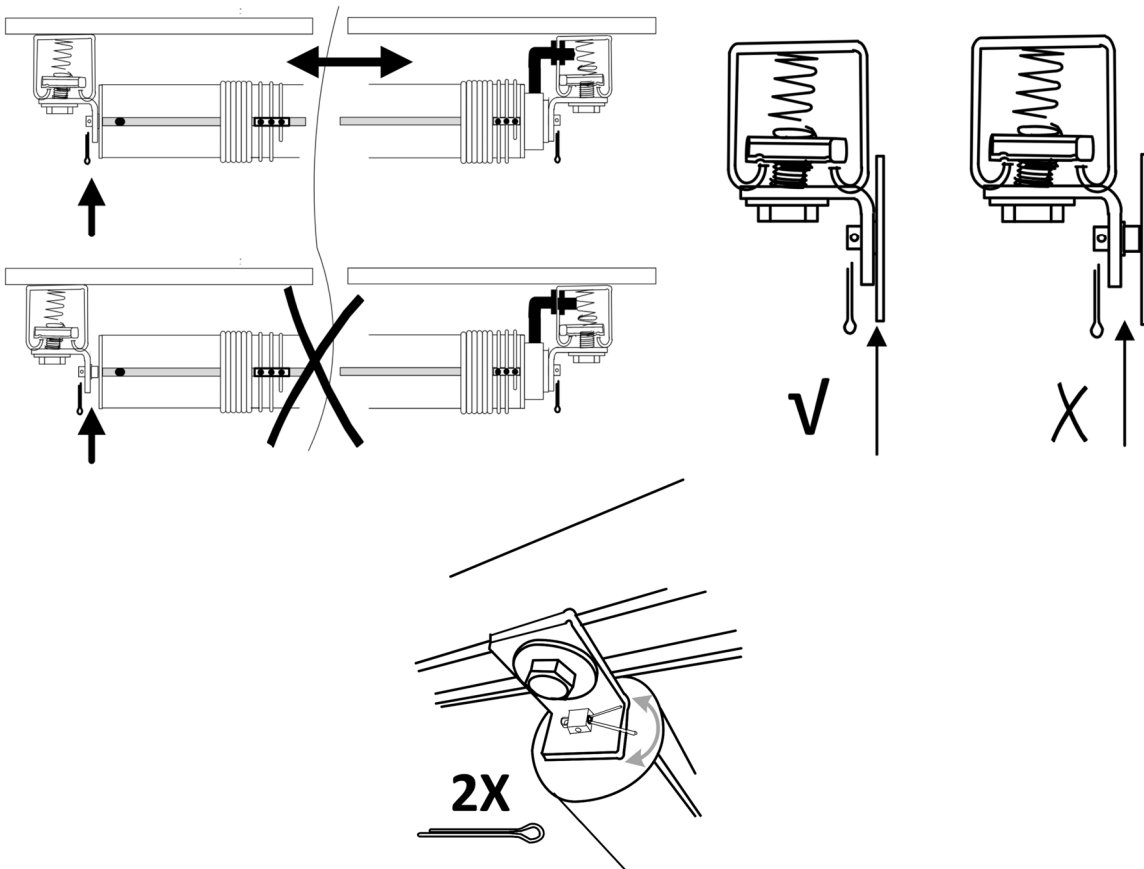

⚠ SHOCK HAZARD
Disconnect power before working on wiring!

6.4 Power Outlet Routing

1. Route the power cable to the nearest standard 120V outlet. Route wiring through pre-drilled strut holes.
2. Install the grommets (03LA) where the cable passes through the strut channel as shown below.
3. Use the cable connectors (3x) to connect the motor and outlet cables – black, white, green.

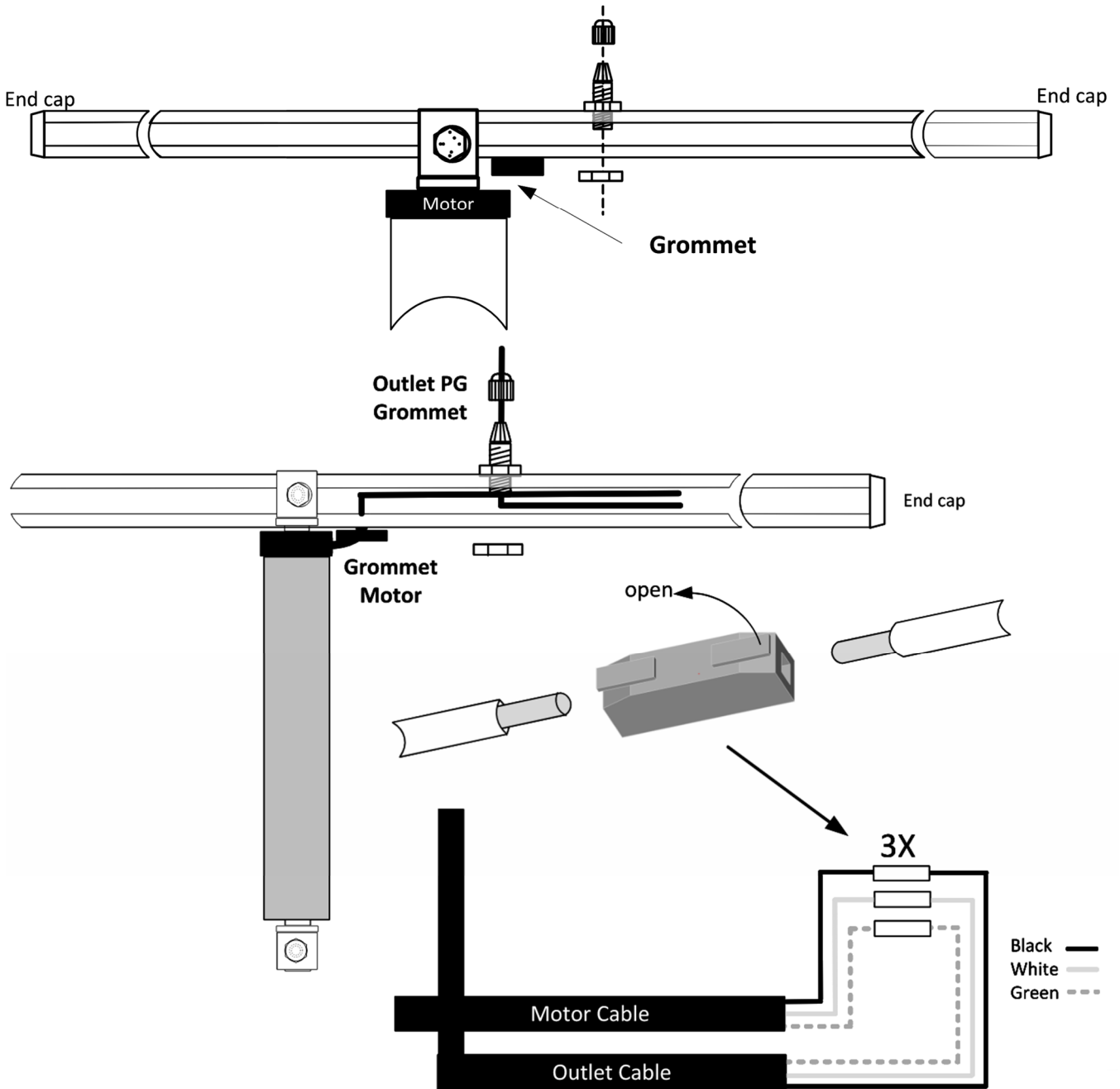

⚠ GROMMETS REQUIRED
Use grommets on ALL wire paths into struts to avoid wire damage and shock hazard.

7. Step 3: Wire Rope and Track (Beam) Install

7.1 Unrolling the Wire Rope

1. Cut the middle cable tie on the motor carefully.
2. Unroll the wire rope from the tube until it hangs 3-feet above the floor.

WIRE ROPE SAFETY

⚠ Never cut the wire rope! Even without tension, the cable wraps must be neatly side by side with no overlapping.

Cable in direction ceiling

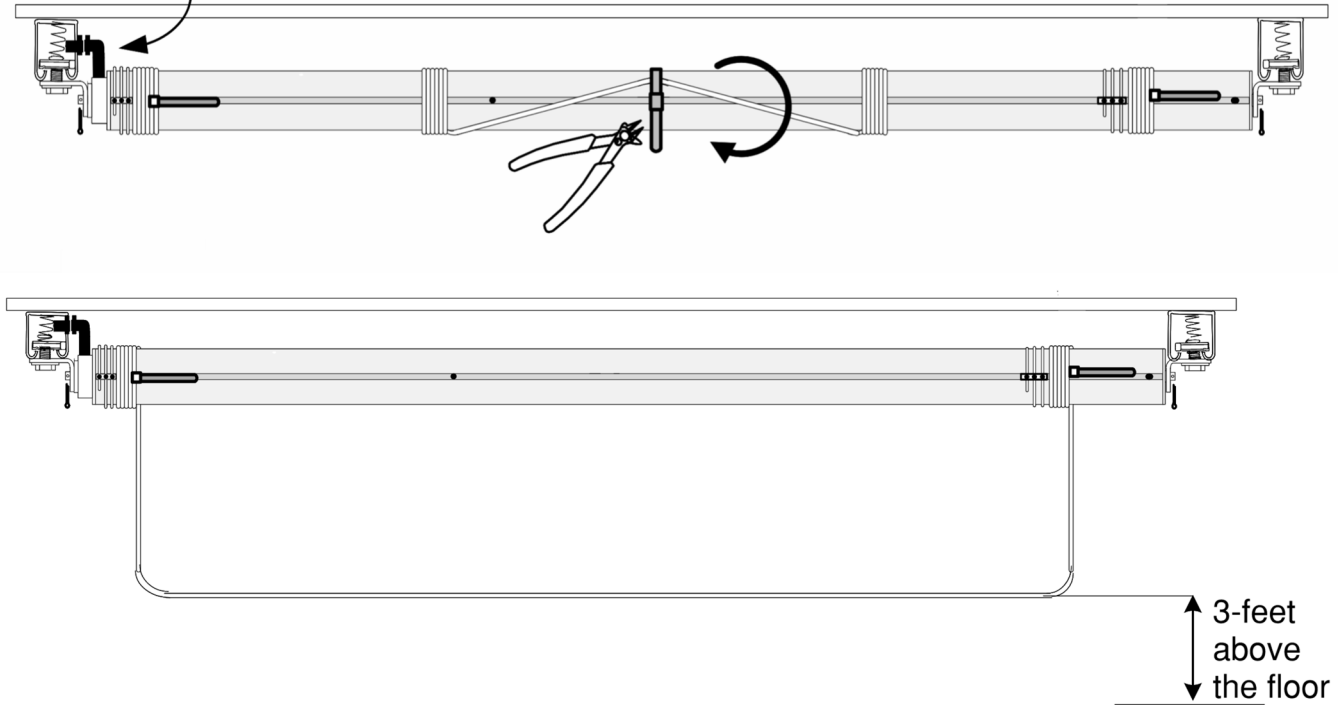

7.2 Assemble the Track Beam

1. Lay out the (2x) track beams (02DA, 5' length) on the floor.
2. Install (12x) M6x14 screws (063A) and (8x) M6 nuts (071A) to the track beams as indicated by the arrows below to lock the two track beams together.
3. Attach the left and right cable guide holder assemblies (2x each side) using (8x) M6x20 screws (06HA) as indicated by the arrows below. Thread the wire ropes through the cable guide assemblies.
4. Do **NOT** tighten the M5x12 setting screws (069A) yet.

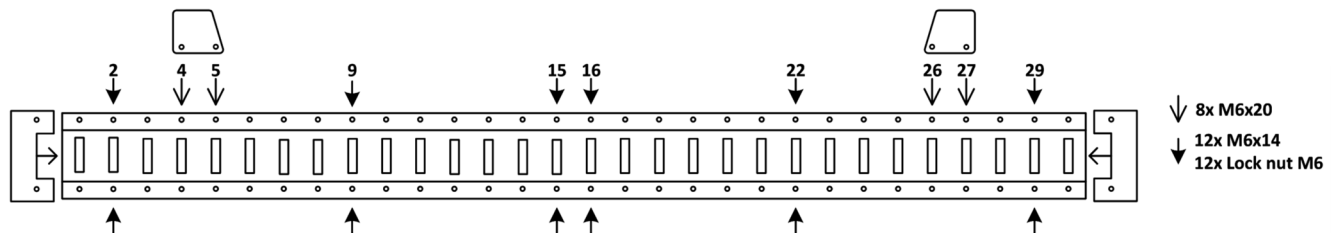

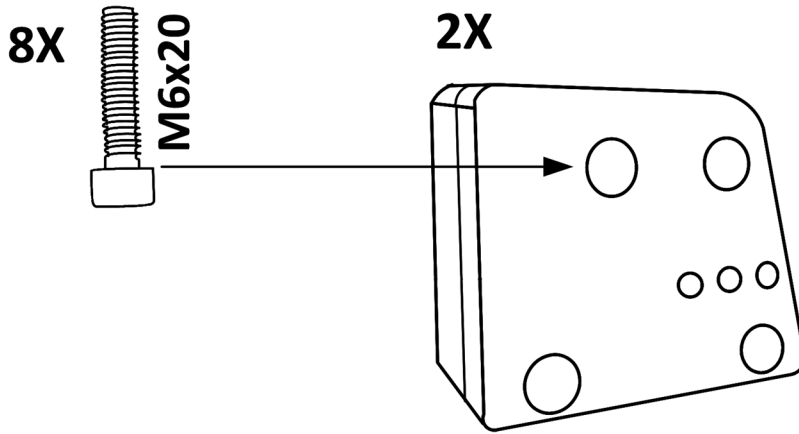

5. Level the track beam.

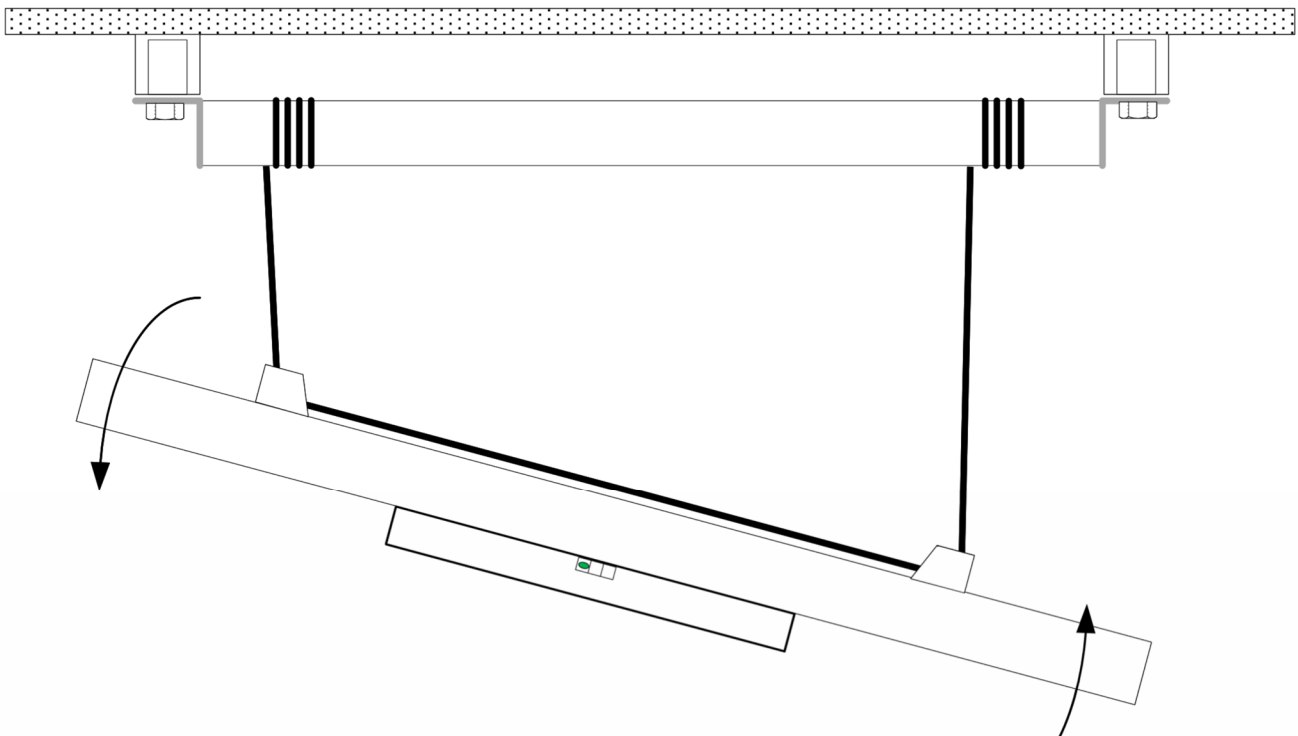

6. Now tighten the M5x12 setting screws (069A).

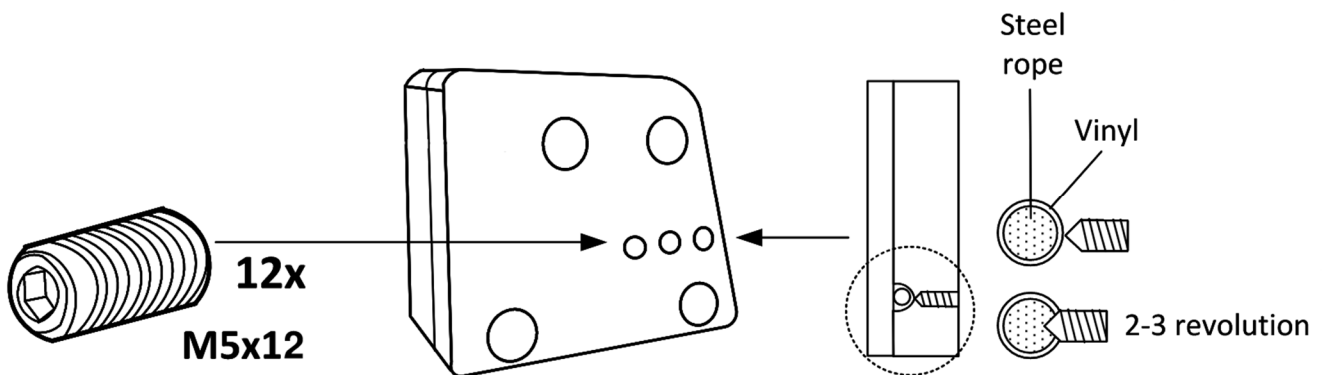

8. Step 4: Motor Adjustment

Controller is built into the motor

i Unlike the standard Auxxlift, the Auxxlift One has the controller integrated inside the motor housing. All mode changes and adjustments are controlled via the remote and the adjustment screws on the motor body.

8.1 Remote Control

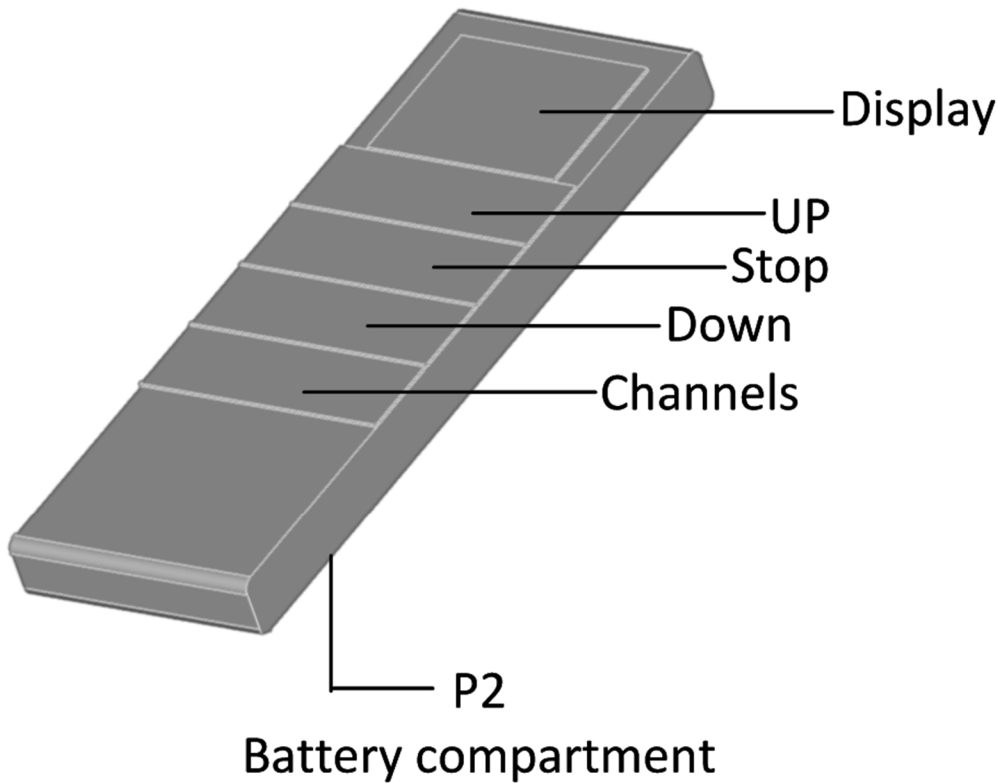

8.2 Screw Locations

The motor has two adjustment screws, accessed from below (view looking toward the ceiling):

Adjustment Screw	Location	Controls	Direction for + (extend)
Inside screw	Closer to center of lift	Ceiling adjustment	Clockwise (+)
Outside screw	Farther from center	Floor adjustment	Clockwise (+)

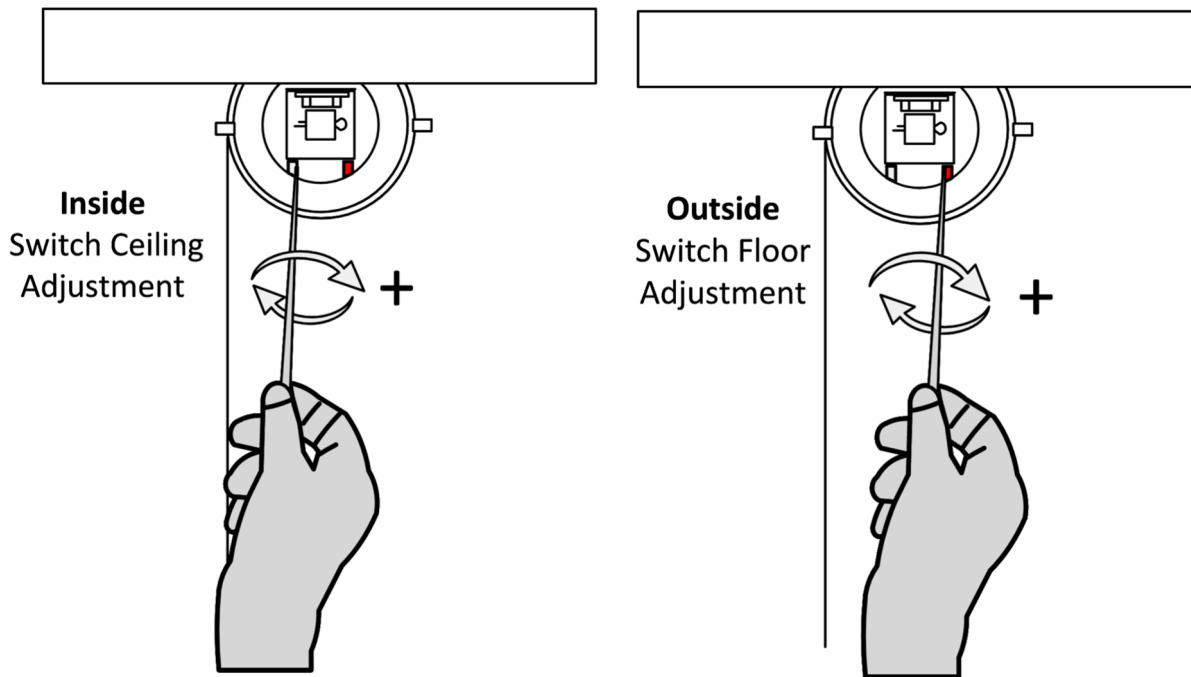

8.3 Understanding + and – Directions

- **+ (clockwise): Extends travel range — platform stop-point moves closer to ceiling or floor.**
- **– (counter-clockwise): Reduces travel range — platform stop-point moves away from ceiling or floor.**

i During initial adjustment: ONLY turn in the + (clockwise) direction. The – direction is used ONLY for troubleshooting and resetting limits.

8.4 Adjustment Overview

Step 1: Initial Setting

1. Confirm that the lift is wired correctly and functional.
2. Set the remote control to “Normal” mode 2. (Adjustments are only possible in that mode)
 - a. Remove the battery from the remote control.
 - b. Hold P2 button on the remote, and reinstall battery while holding P2.
 - c. The display shows "1" (DeadMan active) or "2" (Normal mode).
 - d. If display shows "1": Press the < > buttons and hold for 5 seconds until the screen displays "2" — Normal Mode is now active.

Step 2: Ceiling Adjustment

1. Press UP (button 1) and let the motor run until the platform stops by itself. (PRESS ONCE AND RELEASE - DO NOT HOLD THE BUTTON)
2. Does the platform stop at or before your desired ceiling height?

If NO: (the motor ran past your desired height)

 - a. Press DOWN and let it run 2-feet, press STOP.

- b. Turn the inside adjustment screw in the - (counterclockwise) direction, 30 times.
- c. Press UP and let the motor run until it stops by itself.
- d. Turn the inside adjustment screw in the + (clockwise) direction, until you reach your desired height.

If YES: (the platform stopped at the right point or lower than desired)

- a. Turn the inside adjustment screw in the + (clockwise) direction, until you reach your desired height.

Step 3: Floor Adjustment

1. Press DOWN (button 3) and let the motor run until the platform stops by itself. (DO NOT HOLD THE BUTTON)
2. Does the platform stop at or before your desired floor height?

If NO: (the motor ran past your desired height)

- a. Press UP and let it run 2-feet, press STOP.
- b. Turn the outside adjustment screw in the - (counterclockwise) direction, 30 times.
- c. Press DOWN and let the motor run until it stops by itself.
- d. Turn the outside adjustment screw in the + (clockwise) direction, until you reach your desired height.

If YES: (the platform stopped at the right point or higher than desired)

- b. Turn the outside adjustment screw in the + (clockwise) direction, until you reach your desired height.

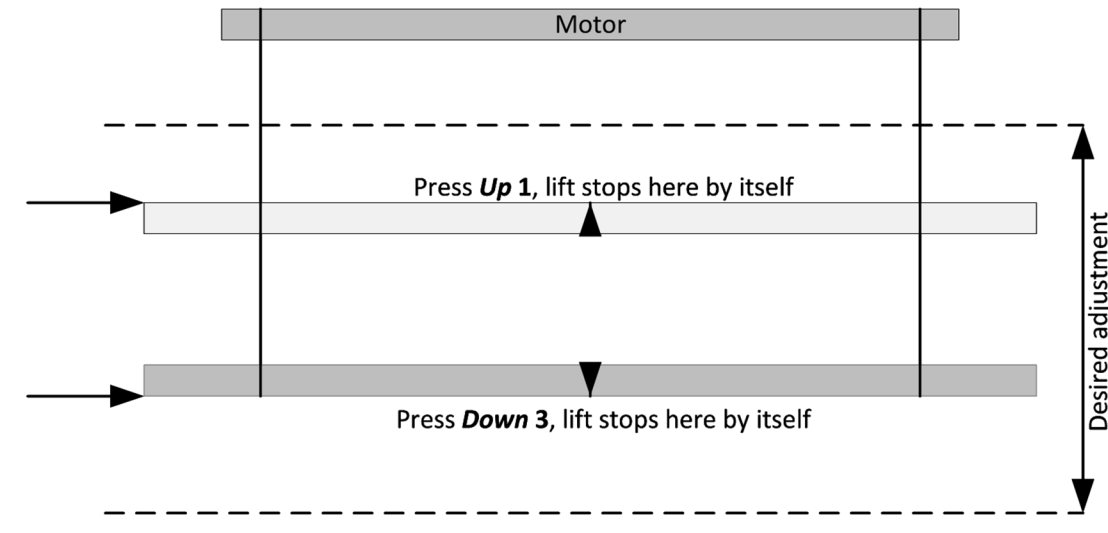

Step 4: Activate Deadman Function

ACTIVATE DEADMAN



After completing all adjustment, you MUST switch DEADMAN Mode (Mode 1) back to on before normal use. This is a critical safety feature. In DeadMan Mode (Mode 1), you must hold the UP or DOWN button continuously for the lift to move. The lift stops immediately when you release the button. If a button gets jammed, press STOP to override.

1. Remove the battery from the remote control.
2. Hold P2 button on the remote and re-install the battery while holding P2.
3. The display shows "1" — DeadMan Mode is now active.

9. Step 5: Covers & Wire Mesh

9.1 Install Strut Covers

1. Slide the cover (1x) (013A) over any exposed strut channel sections. Trim to fit if necessary.
2. Attach end caps to both ends of each strut (4x) (03EA).
3. Verify the covers click securely into place.

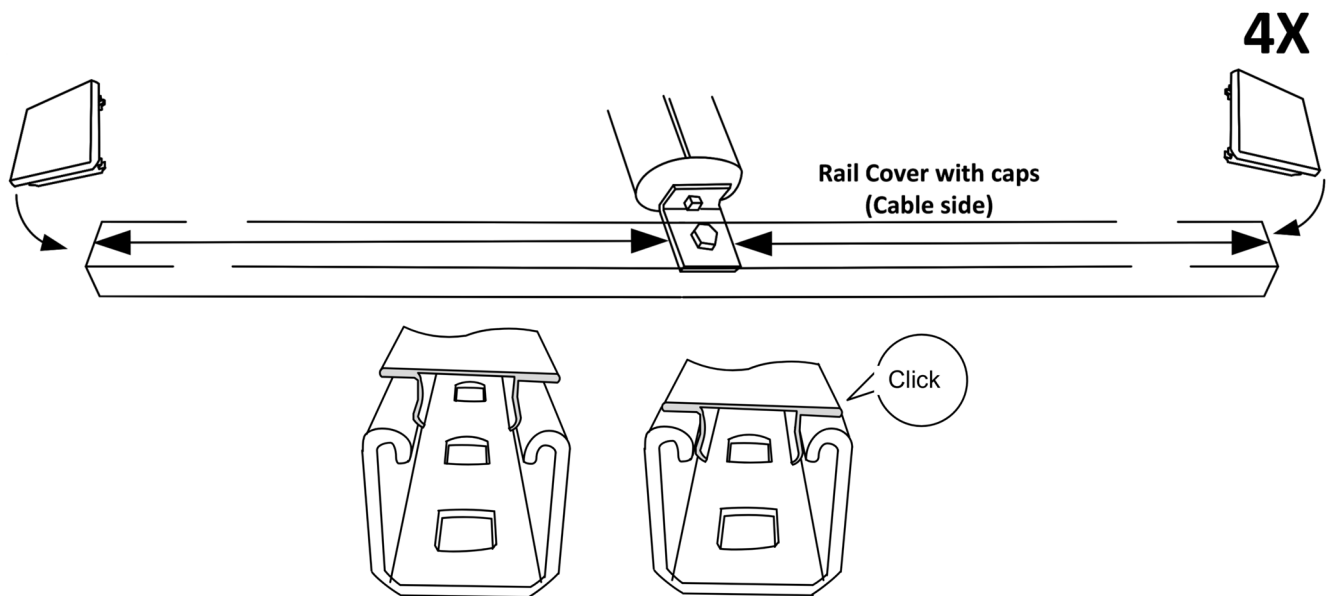

10. Inspection Checklist

Complete this checklist after installation and once per year thereafter. Mark alignment marks on parts that might shift over time (like the motor mount) using a permanent marker. Inspect all items, especially movement at alignment marks, annually.

#	Item	Qty	Done
1	Lag screws tightened	4x	<input type="checkbox"/>
2	Cotter pins installed and opened up	2x	<input type="checkbox"/>
3	12 mm bracket screws tightened	2x	<input type="checkbox"/>
4	All set screws tightened (motor area)	12x	<input type="checkbox"/>
5	All 6 mm screws tightened	12x	<input type="checkbox"/>
6	Electrical wires in correct order	3x	<input type="checkbox"/>
7	Electrical wires not laying on sharp corners	—	<input type="checkbox"/>
8	All set screws tightened (frame area)	8x	<input type="checkbox"/>
9	Gap between the bracket and motor does not exceed 1/16" (1 mm)	—	<input type="checkbox"/>
10	DEADMAN function activated (DM = ON)	—	<input type="checkbox"/>
11	Grommets installed on all wire paths	—	<input type="checkbox"/>

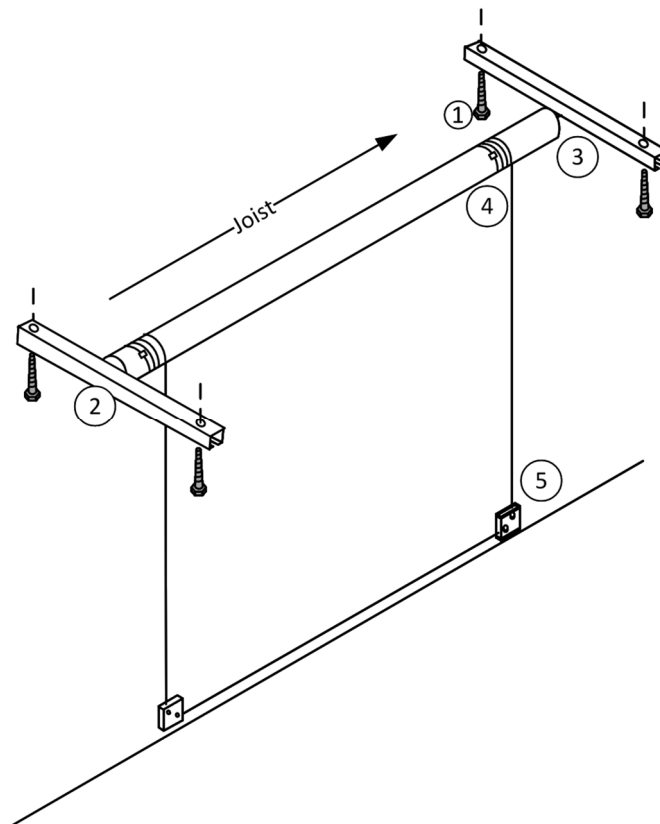

11. Remote Control Programming

The Auxxlift One uses a remote control with an integrated display. The battery is CR 2450 / 3V. Reference diagram below.

11.1 Remote Control Layout

Button / Feature	Function
^ (UP)	Raises the platform
– (STOP)	Stops the platform immediately
v (DOWN)	Lowers the platform
< > (Channel)	Selects which lift (1–15) to control
P2	Programming / mode button (inside battery compartment)
Display	Shows channel number and mode: 1 = DeadMan, 2 = Normal
Battery	CR 2450 / 3V (in battery compartment)

11.2 Pair Remote to Motor Controller

Follow these steps to pair the remote to the Auxxlift One motor controller. Timeout between steps is 5 seconds maximum. If it doesn't work, wait and repeat the steps.

1. Select Channel: Press < > to select the channel number (1–15) you want to assign to this lift.
2. Power the motor: Plug in or switch on the motor. The motor will jog 2 times to confirm it is powered.
3. Enter Pairing mode: Push and hold STOP (–). The motor will jog 4 times — then release STOP.

11.3 Normal Mode vs. DeadMan Mode

The remote has two operating modes, switched by removing and reinserting the battery while holding P2.

1. Remove the battery from the remote control.
2. Hold P2 button on the remote, and reinstall battery while holding P2.
3. The display shows "1" (DeadMan active) or "2" (Normal mode).
4. If the display shows the wrong mode: press < > and hold for 5 seconds until the screen shows the mode. The display will switch to the other mode.

ALWAYS RETURN TO DEADMAN MODE AFTER ADJUSTING



After any adjustment session, switch back to DeadMan Mode (Mode 1) before loading the platform or leaving it unattended.

11.4 Set Number of Channels (Multiple Lifts)

If you are controlling multiple Auxxlift units with one remote, configure the maximum number of channels:

1. Press < > and hold for 5 seconds until the screen shows [(bracket symbol).
2. Select the number of maximum lifts using the channel buttons.

3. Press STOP — the screen shows □ (square).

11.5 Delete All Remote Pairings

Use this only if you need to completely reset the remote pairings:

1. Press P2 — motor jogs 1 time, beeps 1 time.
2. Press STOP — motor jogs 1 time, beeps 1 time.
3. Press P2 — motor jogs 4 times, beeps 3 times.
4. All pairings deleted.

11.6 Jog Mode / Continuous Mode

The remote can toggle between Jog Mode (motor runs only while button is held) and Continuous Mode (motor runs until next button press or stop):

1. Press P2 — motor jogs 2 times, beeps 1 time.
2. Press UP ^ — motor jogs 2 times, beeps 1 time.
3. Press DOWN — motor jogs 4 times, beeps 3 times.
4. Pairing complete.

11.6 Summary Table of all Modes

Pair Remote Motor controller	Normal and Deadman Mode	Set Number Of Channels	Delete All Remotes	Jog Mode/ Continuous Mode	Direction
<div style="border: 1px solid black; padding: 5px; text-align: center;"> Selcet channel 1-15 </div>	<div style="border: 1px solid black; padding: 5px; text-align: center;"> Battery out </div>	<div style="border: 1px solid black; padding: 5px; text-align: center;"> Press < > Hold 5 s In screen [</div>	<div style="border: 1px solid black; padding: 5px; text-align: center;"> Press P2 1 Jog and 1 beep </div>	<div style="border: 1px solid black; padding: 5px; text-align: center;"> Press P2 2 jog 1 beep </div>	<div style="border: 1px solid black; padding: 5px; text-align: center;"> Press ^ + v 5s 4 jog 3 beep </div>
<div style="border: 1px solid black; padding: 5px; text-align: center;"> Power the motor 2 jogs </div>	<div style="border: 1px solid black; padding: 5px; text-align: center;"> Hold P2 and install the battery </div>	<div style="border: 1px solid black; padding: 5px; text-align: center;"> Select number of max lifts </div>	<div style="border: 1px solid black; padding: 5px; text-align: center;"> Press Stop 1 jog and 1 beep </div>	<div style="border: 1px solid black; padding: 5px; text-align: center;"> Press UP ^ 2 jog 1 beep </div>	
<div style="border: 1px solid black; padding: 5px; text-align: center;"> Push Stop and hold Motor jogs 4 times </div>	<div style="border: 1px solid black; padding: 5px; text-align: center;"> Display shows 1 Deadman activ </div>	<div style="border: 1px solid black; padding: 5px; text-align: center;"> Press Stop - In screen □ </div>	<div style="border: 1px solid black; padding: 5px; text-align: center;"> Press P2 4 jogs 3 beeps </div>	<div style="border: 1px solid black; padding: 5px; text-align: center;"> Press Down v 4 jogs 3 beeps </div>	
	<div style="border: 1px solid black; padding: 5px; text-align: center;"> Display shows 2 Normal mode </div>				